

“It’s vital to get grease into the spaces between the thrust washers, and not just on to the shell bearings on which the wheel pivots”

David Etty

A steer on trailer axle maintenance

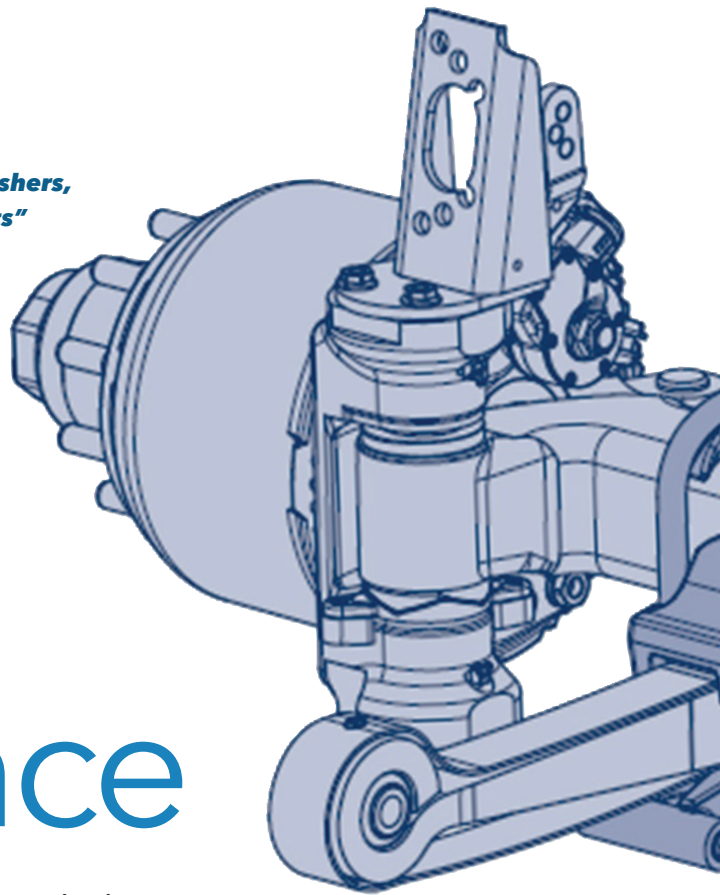

Longer semi-trailers are here to stay after successful trials showed them to be as safe as conventional designs in operation, and as well effective in reducing truck miles, and therefore pollution, cost and road risk.

Instrumental in their success has been the self-steering axle, which allows them to conform to UK turning circle requirements. This technology is also found on other specialist trailers, including low-loaders and urban artics.

Many of these trailers feature BPW axles. German-owned BPW produces product for the British market in Leicestershire and supplies most of the leading trailer manufacturers in the UK. The most cost-effective solution for most applications is the LL axle (pictured above), which requires no external hydraulic or electrical inputs.

HOW THEY WORK

The principles behind the product are not actually a great deal more sophisticated than those of the supermarket trolley castor: trailing wheels are free to pivot on a vertical axis, although the wheels of each axle are connected by drag-link to maintain the Ackermann angle and follow a radius around the same central point.

This allows the trailer wheels to

How a simple process can maintain component life on self-steering trailer axles. By Richard Simpson

conform closely to the track of the tractor unit when moving forward: benefits include not only a tight turning circle, but also reduced tyre wear and fuel consumption.

But that flexibility brings with it two problems: stability moving forwards, and the ability to straight-line and turn predictably in reverse.

The latter of these is simply resolved by locking the steering up when reverse is engaged via a pin in the drag-link actuated from the trailer’s reversing lamp circuit.

The first issue is rather more problematic, but is solved by using technology borrowed from the humble rising-butt door hinge to return the wheel to the straight-ahead position. Thrust washers incorporating cams are built into the pivots that connect the axle beam with the wheel hubs. The cams keep the wheels in line when the tractor-trailer combination is travelling in a straight line. When a cornering force is applied as the tractor unit is steered into a bend, the trailer wheels castor-steer as the force overcomes the resistance of the cams on the thrust washers. When the steering force diminishes as the

combination comes out of the corner, the weight of the trailer and load serve to force the wheel pivots back down the cam into a straight-ahead position. Usefully, the heavier the load is on the axle, the more stable it becomes.

SERVICE

So, what can possibly go wrong? David Etty is a technical engineer working with BPW supporting British trailer-makers who fit the product. He says that the pivots themselves are reliable, but are subject to obvious wear and tear, given the high loads imposed on them and the dirty environment in which they operate. Regular greasing is a necessity, but just applying a grease line to the nipples installed top and bottom will be insufficient.

“It’s vital to get grease into the spaces between the thrust washers, and not just on to the shell bearings on which the wheel pivots,” he warns. “These washers have wearing surfaces: if they wear down, then the self-centring effect will diminish.

“The axle must be jacked up so the road wheels are clear of the ground. Then each wheel must be turned on

TRACTION ACTION

Trailers have always been the poor relations of transport. Drivers may be allocated a particular truck which they regard as their own, but does anyone take 'ownership' of a trailer?

Trailers are far more likely to be regarded as mere rolling-stock, anonymous when they are working correctly and a nuisance when they are not.

That might be a view which is widespread across the industry, but it's not one which is shared by the traffic commissioners. In their annual report for 2020/21, the English TCs noted a sharp increase in operators offering traction services to forwarders and internet retailers, driven by Brexit and the rise in online shopping, and warned that traction operations posed a compliance challenge to both the traction provider and the trailer operator.

While the trailer owner is normally responsible for routine maintenance, including safety inspections, traffic commissioners stress that the operator must comply with the obligations of the operator's licence, which extend to the trailer, whilst it is being used by them, the report warns.

The TCs expect trailer fleets and traction operators to "work together to ensure the roadworthiness of the trailer. The operator should take a risk-based approach to ensure the trailer's maintenance arrangements comply with their own schedule of maintenance and inspections, including regular brake testing," they wrote.

Leasing company TIP believes it has a solution that allows all interested parties to ensure that trailers have been maintained in a safe condition. The multinational company owns over 4,000 trailers in the hands of customers in the UK, part of a European fleet of 14,000, plus 21 workshops in the UK and Ireland.

Previously it used a simple tracking system to locate its assets and monitor



their mileage. But in 2020 this was updated to become TIP Insight, and now covers many aspects of trailer condition and position, including harvesting data from the ABS system regarding brake condition and efficiency, and using tyre-pressure and temperature sensors to warn of leaking tyres, failing wheel bearings and overheating brakes, in addition to GPS location. The information is shared with the operator.

Ian Edmundson, the company's marketing manager for UK and Ireland, says: "Ultimately it will cover our entire fleet or thereabouts, plus customer-owned assets that we look after."

Cost-savings are considerable, although difficult to quantify, Edmundson admits.

Data can highlight individual driver behaviour: a higher-than-normal incidence of harsh braking could indicate poor anticipation. It can also detect trailer overloading: in both cases, if uncorrected, these will lead to greater wear and tear on trailer and tractor unit.

The data harvested from the growing number of TIP assets covered by TIP Insight can be compared with real-life experience to establish "not just where the trailer is, but how the trailer is," he adds.

These means that reactive maintenance to replace failed components becomes predictive: a technician can not only replace worn or defective parts, but also have a good idea of what other components might require attention before the trailer's next inspection and act accordingly.

A manifestation of this is the BrakePlus feature monitoring trailer brake performance. It sounds alerts if a brake's performance declines, and is said to be an acceptable substitute for a brake roller test.

-Richard Simpson 

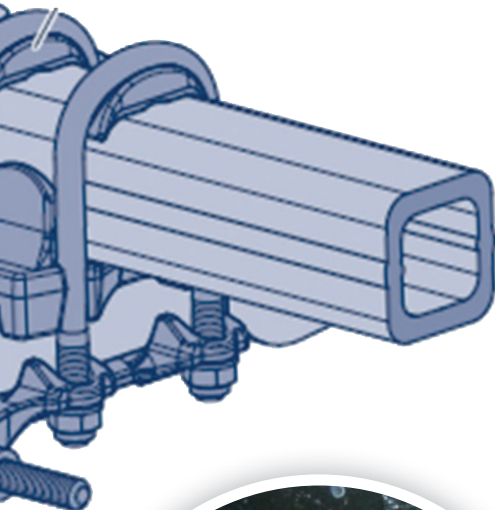

its steering pivot while the grease is applied so the cams ride over each other. The application should continue until fresh grease appears between the washers. Ideally, you'd have the trailer over a pit."

He recommends that the application be made at six-weekly intervals, regardless of mileage.

"Trailers that cover low mileages are often those that do the most arduous work: particularly in urban and off-highway applications."

The type of grease used is also important. "We developed our own synthetic formula at BPW; it's a very sticky grease designed to maintain a strong film on the cams. When it comes to lubricants, cheap really isn't cheap." 